

# VERTICAL FLIPPER OPTIONS

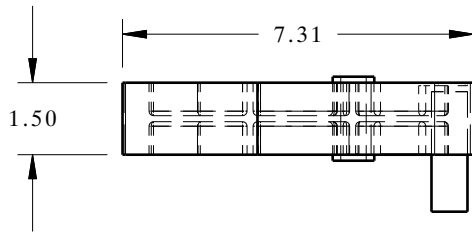

**DE1372 FLIPPER  
2.50" INDEX**

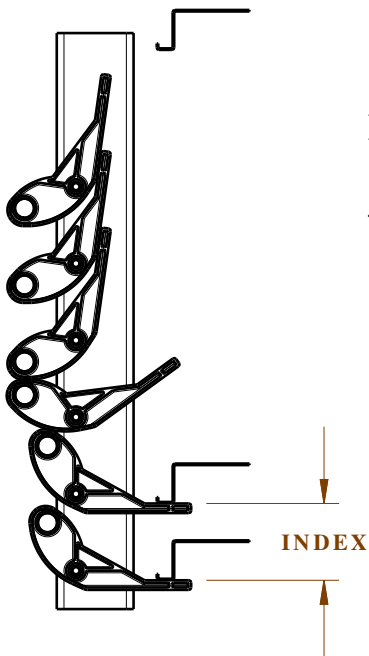
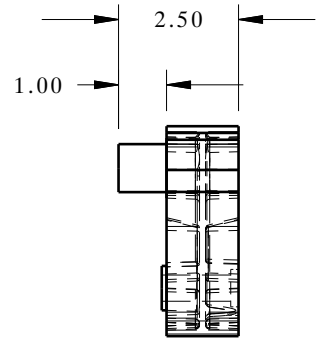
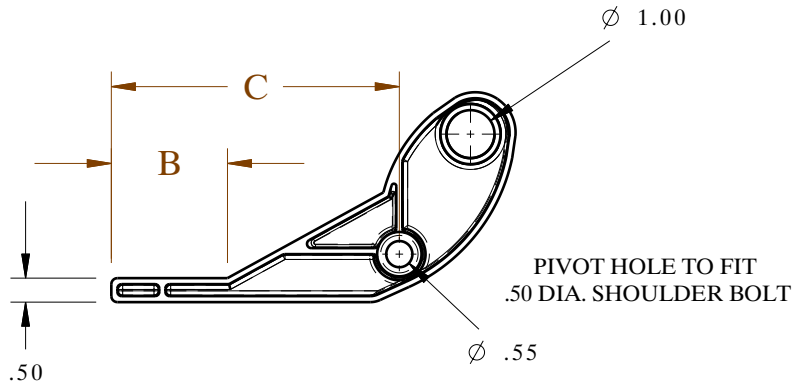
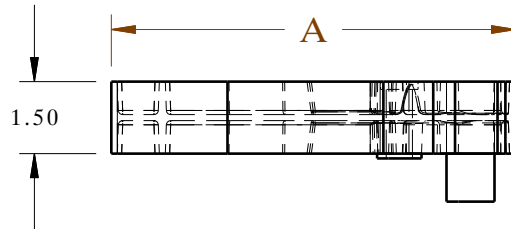
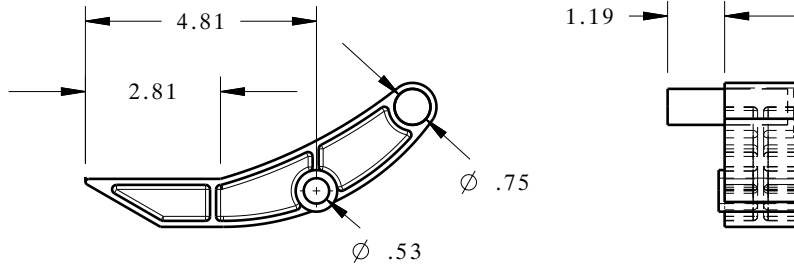

Tool Number	Index	Dim A	Dim B	Dim C
DE1015	3.00"	7.27"	2.44"	5.00"
DE1371 Short	3.00"	7.27"	1.69"	5.00"
DE1371 Long	3.00"	7.77"	2.19"	5.50"
DE740 Short	4.00"	7.42"	1.42"	5.00"
DE740 Long	4.00"	8.42"	2.42"	6.00"
DE1480	4.00"	8.43"	4.50"	6.02"

<b>MATERIAL TYPE</b> PC/ PBT
<b>HARDNESS</b> N/A
<b>COLOR</b> Black, others upon request

**VERTICAL STYLE FLIPPER**  
**Application:**  
 Vertically load and unload panels  
 in horizontal part orientation

**800-443-5553**      [www.dunnage-eng.com](http://www.dunnage-eng.com)