

DE946 PADDLE

INDEX: 2.00" +

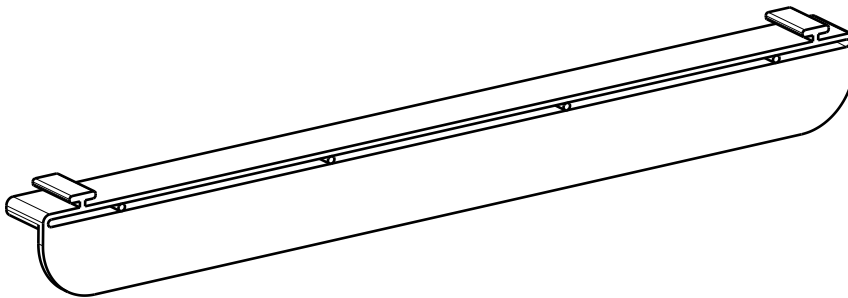

FOR GREATER THAN 2.00" INDEX
USE A LASER CUT PLATE ON BOTH SIDES

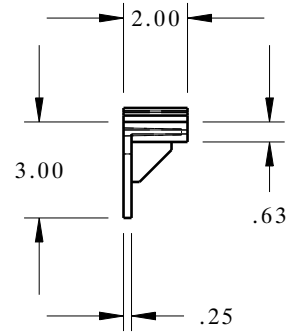
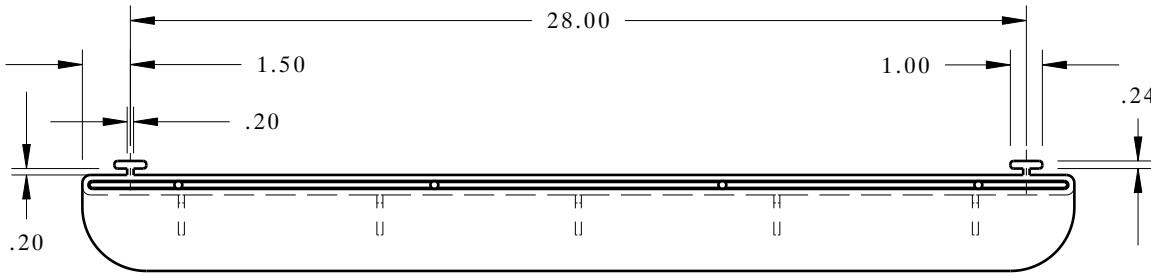
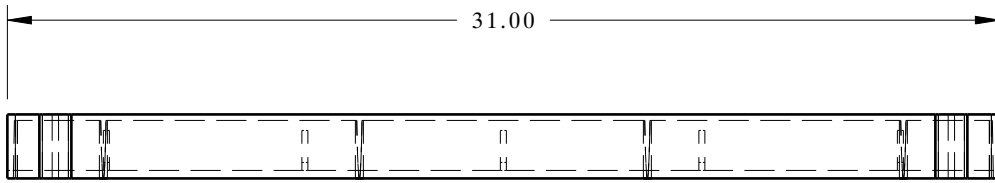
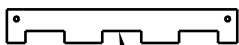

NOTCHES SET INDEX

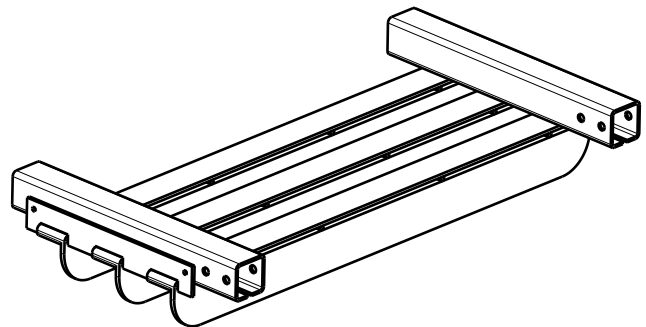

MATERIAL TYPE Polypropylene with 20% talc
HARDNESS N / A
COLOR As Requested (Black Std.)

DE946 PADDLE INDEX : 2.00" +
Applications: Part Loading Aid Part Separation



800-443-5553 www.dunnage-eng.com