

DE56 PADDLE

Multiple Configurations

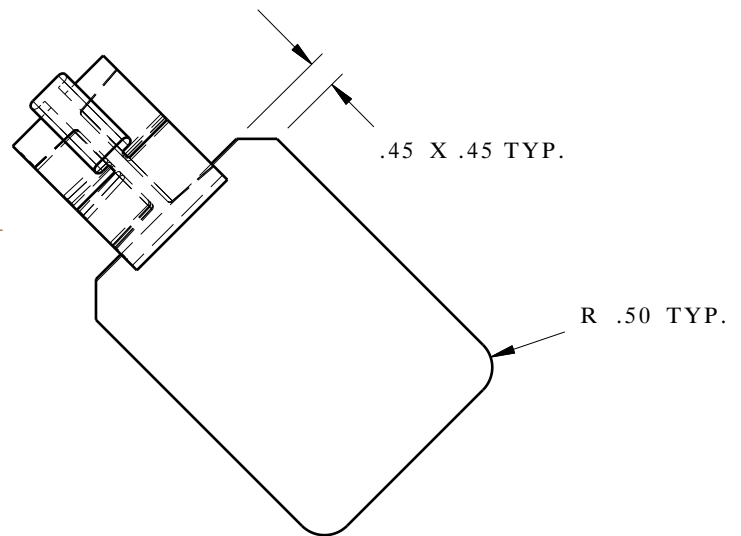
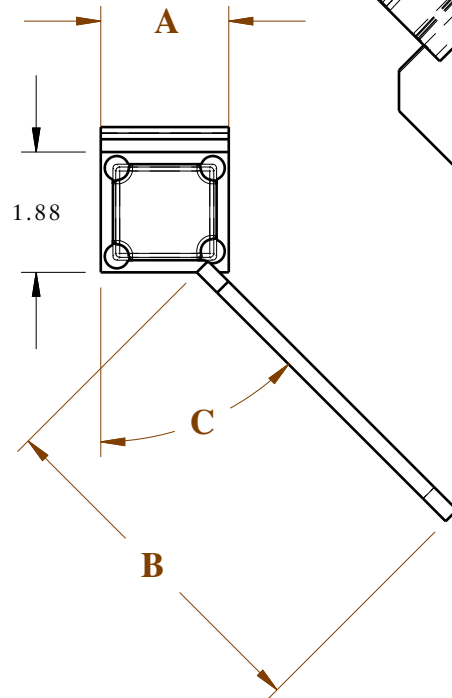
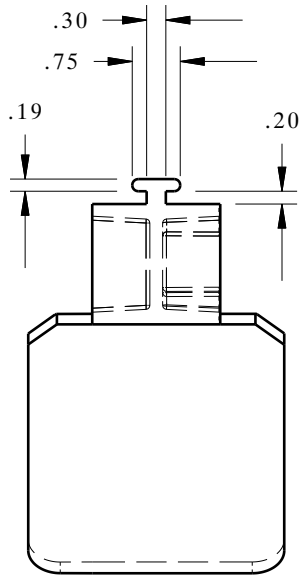
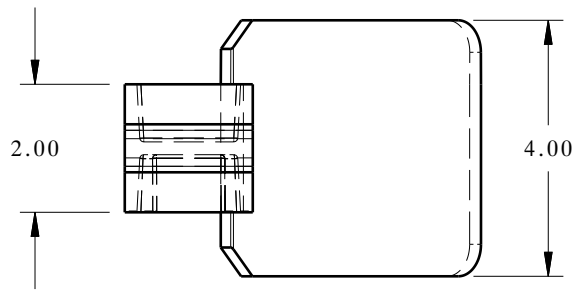

Paddle Configurations

Tool Code	Length Dim "B"	Angle Dim "C"	Index Option Dim "A"
DE56-A	3.13"	40	1.75", 2.00", 2.50"
DE56-B	3.38"	45	1.75", 2.00", 2.50"
DE56-C	5.50"	45	1.75", 2.00", 2.50"
DE56-D	4.00"	40	1.75", 2.00", 2.50"
DE56-E	6.38"	32	1.75", 2.00", 2.50"
DE56-F	2.00"	45	1.50"
DE56-G	4.50"	45	1.50"

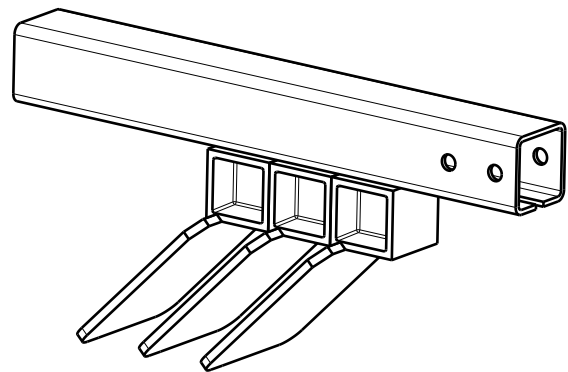

MATERIAL TYPE Polypropylene Co-Polymer
HARDNESS (SHORE A) N/A
COLOR As Requested (Black Std.)

DE56 ADJUSTABLE PADDLE

Applications:

- Part Loading Aid
- Part Separation



Dunnage Engineering

800-443-5553 www.dunnage-eng.com