

DE143 SEPARATOR DUNNAGE

2.00' INDEX

.50' POCKET

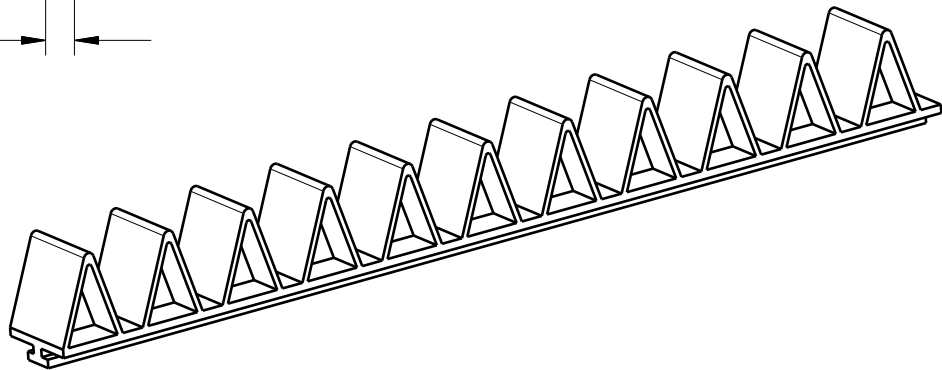
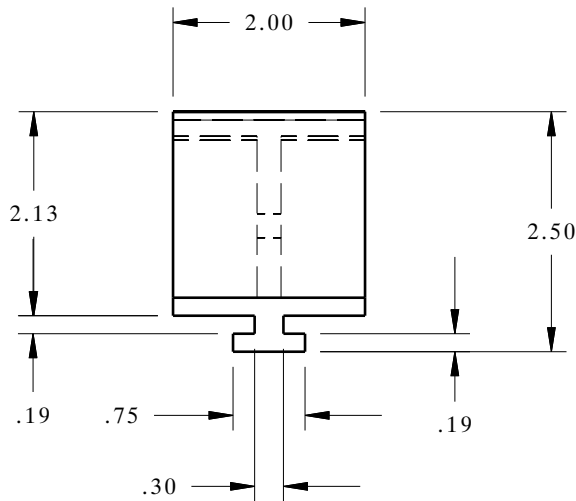
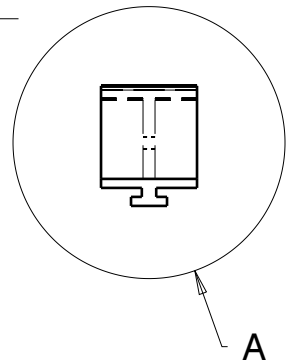
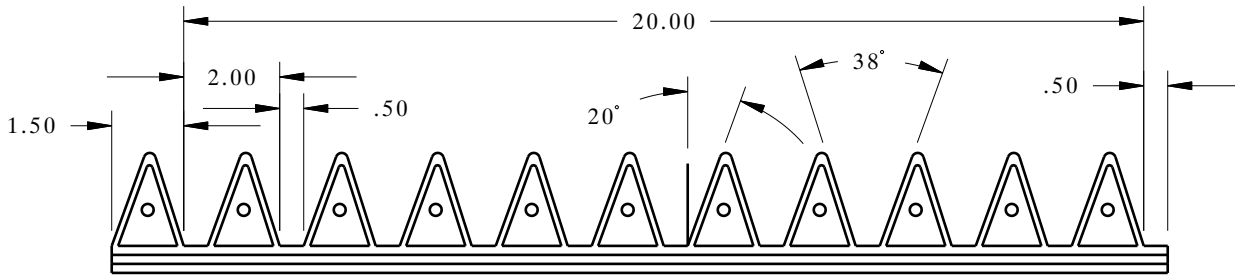
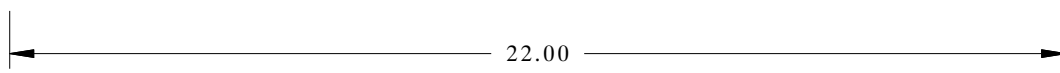
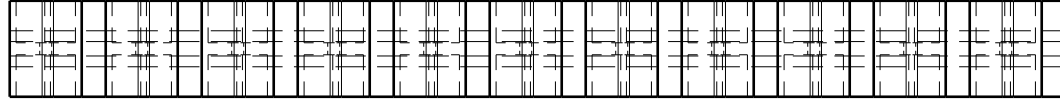

MATERIAL TYPE Thermoplastic Elastomer (TPE)
HARDNESS (SHORE A) 90A , Call
COLOR Grey (STOCK), Call

SEPARATOR DUNNAGE
2.00" INDEX, .50" POCKET

Applications:
- Part Separation



800-443-5553

www.dunnage-eng.com